

250mA Current、15V Input Voltage LDO

H73XX-A

General Description

The H73XX-A series is a set of three-terminal low power high voltage regulators implemented in CMOS technology. They allow input voltages as high as 18V. The series features extremely low quiescent current which is typically 2 μ A. They are available with several fixed output voltages ranging from 1.5V to 5.0V. CMOS technology ensures low voltage drop and low quiescent current. Although designed primarily as fixed voltage regulators, these devices can be used with external components to obtain variable voltages and currents.

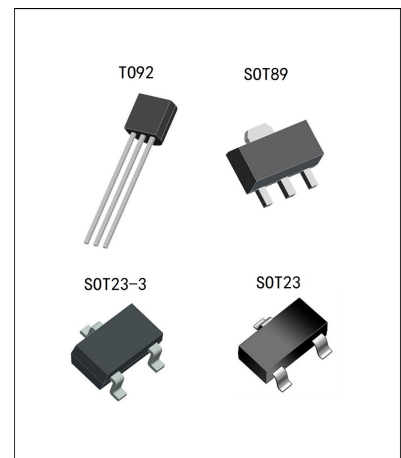

Features

- Low power consumption
- Low voltage drop
- Low temperature coefficient
- Ultra low quiescent current: 2 μ A(typ.)
- High input voltage (up to 15V)
- Maximum output current: 250mA
- Output voltage accuracy: tolerance \pm 2%
- TO92, SOT89, SOT23 and SOT23-3 package

Applications

- Battery-powered equipment
- Communication equipment
- Audio/Video equipment

Order specification

Part No	Package	Manner of Packing	Devices per bag/reel
H73XX-ATX	TO92	Bag	1000PCS/bag
H73XX-APX	SOT89	Reel	1000PCS/reel
H73XX-ANX	SOT23	Reel	3000PCS/reel
H73XX-AMX	SOT23-3	Reel	3000PCS/reel

Description of selection

Part No	Output Voltage	Output Voltage Accuracy
H7315-AXX	1.5V	±2%
H7318-AXX	1.8V	±2%
H7325-AXX	2.5V	±2%
H7328-AXX	2.8V	±2%
H7330-AXX	3.0V	±2%
H7333-AXX	3.3V	±2%
H7336-AXX	3.6V	±2%
H7340-AXX	4.0V	±2%
H7344-AXX	4.4V	±2%
H7350-AXX	5.0V	±2%

Print rules

Package	Marking
TO92	73XX-A
SOT89	73XX-A
SOT23	3XX
SOT23-3	3XX

Note: "XX" stands for output voltages. Other voltages can be specially customized.

Type selection guide

H73①②-A③④

Designator	Symbol	Description
①②	Integer	Output Voltage(1.5~5.0V)
③	T	Package:TO-92
	P	Package:SOT89
	N	Package:SOT23
	M	Package:SOT23-3
④	R	RoHS / Pb Free
	G	Halogen Free

Block Diagram and Pin Arrangement Diagram

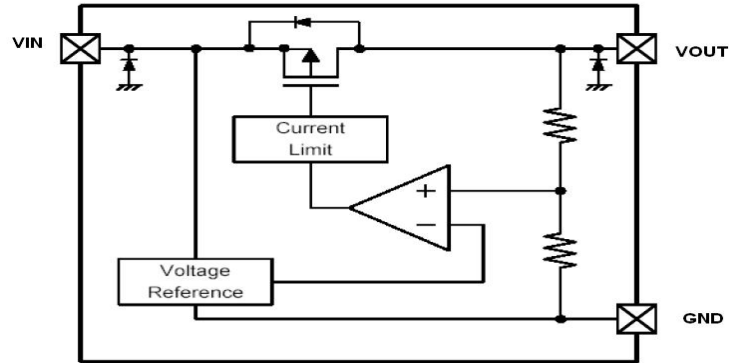

*Diodes inside the circuit are an ESD protection diode and a parasitic diode.

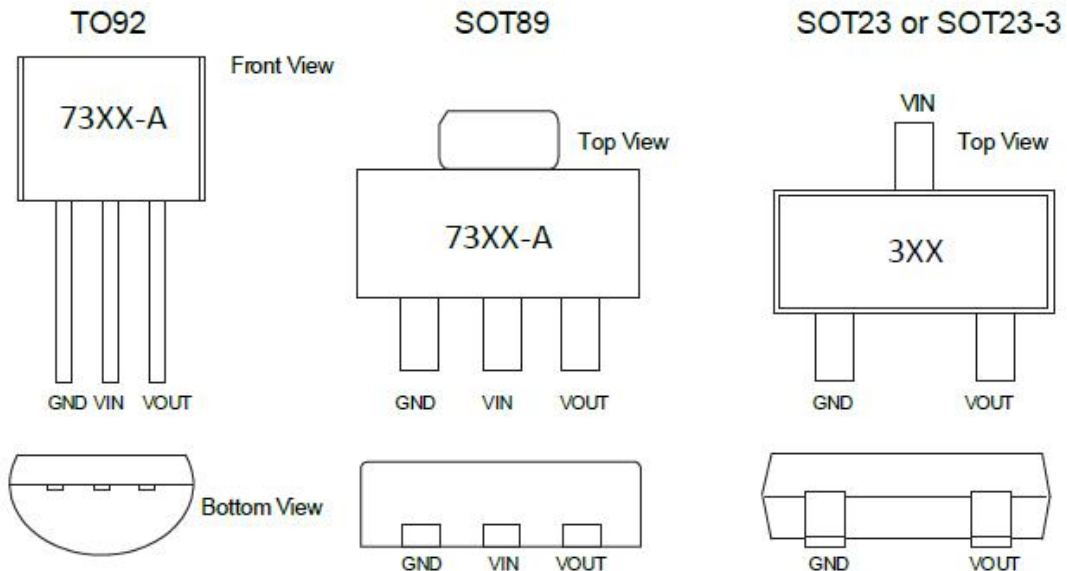

Pin Assignment

Pin No.	Pin Name	Description
1	GND	Ground connection.
2	VIN	Supply Voltage Input.
3	VOUT	Output.

Functional Description

The H73XX-A series is a set of three-terminal low power high voltage regulators implemented in CMOS technology. They allow input voltages as high as 18V. They are available with several fixed output voltages ranging from 2.5V to 5.0V.

Absolute Maximum Ratings

Parameter	Symbol	Value	Unit
Supply Voltage Input	V _{IN}	-0.3~18	V
Operating Temperature	T _{amb}	-30~85	°C
Storage Temperature	T _{stg}	-50~125	°C

Note: These are stress ratings only. Stresses exceeding the range specified under “Absolute Maximum Ratings” may cause substantial damage to the device. Functional operation of this device at other conditions beyond those listed in the specification is not implied and prolonged exposure to extreme conditions may affect device reliability.

Thermal Information

Parameter	Symbol	Package	Max.	Unit
Thermal Resistance (Junction to Ambient) (Assume no ambient airflow, no heat sink)	θ_{JA}	SOT23	500	°C/W
		SOT89	200	°C/W
		TO92	200	°C/W
Power Dissipation	P _D	SOT23	0.20	W
		SOT89	0.50	W
		TO92	0.50	W

Note: P_D is measured at T_a= 25°C.

Electrical Characteristics

H7315-A, +1.5V Output Type

Parameter	Symbol	Test Conditions		Min.	Typ.	Max.	Unit
		V _{IN}	Conditions				
Output Voltage	V _{OUT}	3.5V	I _{OUT} =40mA	1.470	1.500	1.530	V
Output Current	I _{OUT}	3.5V	-	-	250	-	mA
Load Regulation	ΔV _{OUT}	3.5V	1mA ≤ I _{OUT} ≤ 60mA	-	45	90	mV
Voltage Drop(Note)	V _{DIF}	-	I _{OUT} =40mA ΔV _{OUT} =2%	-	100	-	mV
Current Consumption	I _{SS}	3.5V	No load	-	2.0	3.0	μA
Line Regulation	$\frac{\Delta V_{OUT}}{\Delta V_{IN} \times V_{OUT}}$	-	2.5V ≤ V _{IN} ≤ 12V I _{OUT} =40mA	-	0.2	-	%/V
Input Voltage	V _{IN}	-	-	-	-	15	V
Temperature Coefficient	$\frac{\Delta V_{OUT}}{\Delta T_a}$	3.5V	I _{OUT} =40mA -40°C < T _a < 85°C	-	± 0.5	-	mV/°C

Note: Dropout voltage is defined as the input voltage minus the output voltage that produces a 2% change in the output voltage from the value at V_{IN} = V_{OUT}+2V with a fixed load.

H7318-A, +1.8V Output Type

Parameter	Symbol	Test Conditions		Min.	Typ.	Max.	Unit
		V _{IN}	Conditions				
Output Voltage	V _{OUT}	3.8V	I _{OUT} =40mA	1.764	1.800	1.836	V
Output Current	I _{OUT}	3.8V	-	-	250	-	mA
Load Regulation	ΔV _{OUT}	3.8V	1mA ≤ I _{OUT} ≤ 60mA	-	45	90	mV
Voltage Drop(Note)	V _{DIF}	-	I _{OUT} =40mA ΔV _{OUT} =2%	-	100	-	mV
Current Consumption	I _{SS}	3.8V	No load	-	2.0	3.0	μA
Line Regulation	$\frac{\Delta V_{OUT}}{\Delta V_{IN} \times V_{OUT}}$	-	2.8V ≤ V _{IN} ≤ 12V I _{OUT} =40mA	-	0.2	-	%/V
Input Voltage	V _{IN}	-	-	-	-	15	V
Temperature Coefficient	$\frac{\Delta V_{OUT}}{\Delta T_a}$	3.8V	I _{OUT} =40mA -40°C < T _a < 85°C	-	± 0.5	-	mV/°C

Note: Dropout voltage is defined as the input voltage minus the output voltage that produces a 2% change in the output voltage from the value at V_{IN} = V_{OUT}+2V with a fixed load.

H7325-A, +2.5V Output Type

Parameter	Symbol	Test Conditions		Min.	Typ.	Max.	Unit
		V _{IN}	Conditions				
Output Voltage	V _{OUT}	4.5V	I _{OUT} =40mA	2.450	2.500	2.550	V
Output Current	I _{OUT}	4.5V	-	-	250	-	mA
Load Regulation	Δ V _{OUT}	4.5V	1mA ≤ I _{OUT} ≤ 60mA	-	45	90	mV
Voltage Drop(Note)	V _{DIF}	-	I _{OUT} =40mA Δ V _{OUT} =2%	-	100	-	mV
Current Consumption	I _{SS}	4.5V	No load	-	2.0	3.0	μ A
Line Regulation	$\frac{\Delta V_{OUT}}{\Delta V_{IN} \times V_{OUT}}$	-	3.5V ≤ V _{IN} ≤ 12V I _{OUT} =40mA	-	0.2	-	%/V
Input Voltage	V _{IN}	-	-	-	-	15	V
Temperature Coefficient	$\frac{\Delta V_{OUT}}{\Delta T_a}$	4.5V	I _{OUT} =40mA -40°C < T _a < 85°C	-	± 0.5	-	mV/ °C

Note: Dropout voltage is defined as the input voltage minus the output voltage that produces a 2% change in the output voltage from the value at V_{IN} = V_{OUT}+2V with a fixed load.

H7328-A, +2.8V Output Type

Parameter	Symbol	Test Conditions		Min.	Typ.	Max.	Unit
		V _{IN}	Conditions				
Output Voltage	V _{OUT}	4.8V	I _{OUT} =40mA	2.744	2.800	2.856	V
Output Current	I _{OUT}	4.8V	-	-	250	-	mA
Load Regulation	Δ V _{OUT}	4.8V	1mA ≤ I _{OUT} ≤ 60mA	-	45	90	mV
Voltage Drop(Note)	V _{DIF}	-	I _{OUT} =40mA Δ V _{OUT} =2%	-	100	-	mV
Current Consumption	I _{SS}	4.8V	No load	-	2.0	3.0	μ A
Line Regulation	$\frac{\Delta V_{OUT}}{\Delta V_{IN} \times V_{OUT}}$	-	3.8V ≤ V _{IN} ≤ 12V I _{OUT} =40mA	-	0.2	-	%/V
Input Voltage	V _{IN}	-	-	-	-	15	V
Temperature Coefficient	$\frac{\Delta V_{OUT}}{\Delta T_a}$	4.8V	I _{OUT} =40mA -40°C < T _a < 85°C	-	± 0.5	-	mV/ °C

Note: Dropout voltage is defined as the input voltage minus the output voltage that produces a 2% change in the output voltage from the value at V_{IN} = V_{OUT}+2V with a fixed load.

H7330-A, +3.0V Output Type

Parameter	Symbol	Test Conditions		Min.	Typ.	Max.	Unit
		V _{IN}	Conditions				
Output Voltage	V _{OUT}	5V	I _{OUT} =40mA	2.940	3.000	3.060	V
Output Current	I _{OUT}	5V	-	-	250	-	mA
Load Regulation	ΔV _{OUT}	5V	1mA ≤ I _{OUT} ≤ 80mA	-	45	90	mV
Voltage Drop(Note)	V _{DIF}	-	I _{OUT} =40mA ΔV _{OUT} =2%	-	100	-	mV
Current Consumption	I _{SS}	5V	No load	-	2.0	3.0	μA
Line Regulation	$\frac{\Delta V_{OUT}}{\Delta V_{IN} \times V_{OUT}}$	-	4V ≤ V _{IN} ≤ 12V I _{OUT} =40mA	-	0.2	-	%/V
Input Voltage	V _{IN}	-	-	-	-	15	V
Temperature Coefficient	$\frac{\Delta V_{OUT}}{\Delta T_a}$	5V	I _{OUT} =40mA -40°C < T _a < 85°C	-	± 0.5	-	mV/°C

Note: Dropout voltage is defined as the input voltage minus the output voltage that produces a 2% change in the output voltage from the value at V_{IN} = V_{OUT}+2V with a fixed load.

H7333-A, +3.3V Output Type

Parameter	Symbol	Test Conditions		Min.	Typ.	Max.	Unit
		V _{IN}	Conditions				
Output Voltage	V _{OUT}	5.3V	I _{OUT} =40mA	3.234	3.300	3.366	V
Output Current	I _{OUT}	5.3V	-	-	250	-	mA
Load Regulation	ΔV _{OUT}	5.3V	1mA ≤ I _{OUT} ≤ 80mA	-	45	90	mV
Voltage Drop(Note)	V _{DIF}	-	I _{OUT} =40mA ΔV _{OUT} =2%	-	100	-	mV
Current Consumption	I _{SS}	5.3V	No load	-	2.0	3.0	μA
Line Regulation	$\frac{\Delta V_{OUT}}{\Delta V_{IN} \times V_{OUT}}$	-	4.3V ≤ V _{IN} ≤ 12V I _{OUT} =40mA	-	0.2	-	%/V
Input Voltage	V _{IN}	-	-	-	-	15	V
Temperature Coefficient	$\frac{\Delta V_{OUT}}{\Delta T_a}$	5.3V	I _{OUT} =40mA -40°C < T _a < 85°C	-	± 0.5	-	mV/°C

Note: Dropout voltage is defined as the input voltage minus the output voltage that produces a 2% change in the output voltage from the value at V_{IN} = V_{OUT}+2V with a fixed load.

H7336-A, +3.6V Output Type

Parameter	Symbol	Test Conditions		Min.	Typ.	Max.	Unit
		V _{IN}	Conditions				
Output Voltage	V _{OUT}	5.6V	I _{OUT} =40mA	3.528	3.600	3.672	V
Output Current	I _{OUT}	5.6V	-	-	250	-	mA
Load Regulation	ΔV _{OUT}	5.6V	1mA ≤ I _{OUT} ≤ 80mA	-	45	90	mV
Voltage Drop(Note)	V _{DIF}	-	I _{OUT} =40mA ΔV _{OUT} =2%	-	80	-	mV
Current Consumption	I _{SS}	5.6V	No load	-	2.0	3.0	μA
Line Regulation	$\frac{\Delta V_{OUT}}{\Delta V_{IN} \times V_{OUT}}$	-	4.6V ≤ V _{IN} ≤ 12V I _{OUT} =40mA	-	0.2	-	%/V
Input Voltage	V _{IN}	-	-	-	-	15	V
Temperature Coefficient	$\frac{\Delta V_{OUT}}{\Delta T_a}$	5.6V	I _{OUT} =40mA -40°C < T _a < 85°C	-	± 0.5	-	mV/°C

Note: Dropout voltage is defined as the input voltage minus the output voltage that produces a 2% change in the output voltage from the value at V_{IN} = V_{OUT}+2V with a fixed load.

H7340-A, +4.0V Output Type

Parameter	Symbol	Test Conditions		Min.	Typ.	Max.	Unit
		V _{IN}	Conditions				
Output Voltage	V _{OUT}	6.0V	I _{OUT} =40mA	3.920	4.000	4.080	V
Output Current	I _{OUT}	6.0V	-	-	250	-	mA
Load Regulation	ΔV _{OUT}	6.0V	1mA ≤ I _{OUT} ≤ 80mA	-	45	90	mV
Voltage Drop(Note)	V _{DIF}	-	I _{OUT} =40mA ΔV _{OUT} =2%	-	80	-	mV
Current Consumption	I _{SS}	6.0V	No load	-	2.0	3.0	μA
Line Regulation	$\frac{\Delta V_{OUT}}{\Delta V_{IN} \times V_{OUT}}$	-	5V ≤ V _{IN} ≤ 12V I _{OUT} =40mA	-	0.2	-	%/V
Input Voltage	V _{IN}	-	-	-	-	15	V
Temperature Coefficient	$\frac{\Delta V_{OUT}}{\Delta T_a}$	6.0V	I _{OUT} =40mA -40°C < T _a < 85°C	-	± 0.5	-	mV/°C

Note: Dropout voltage is defined as the input voltage minus the output voltage that produces a 2% change in the output voltage from the value at V_{IN} = V_{OUT}+2V with a fixed load.

H7344-A, +4.4V Output Type

Parameter	Symbol	Test Conditions		Min.	Typ.	Max.	Unit
		V _{IN}	Conditions				
Output Voltage	V _{OUT}	6.4V	I _{OUT} =40mA	4.312	4.400	4.488	V
Output Current	I _{OUT}	6.4V	-	-	250	-	mA
Load Regulation	ΔV _{OUT}	6.4V	1mA ≤ I _{OUT} ≤ 80mA	-	45	90	mV
Voltage Drop(Note)	V _{DIF}	-	I _{OUT} =40mA ΔV _{OUT} =2%	-	80	-	mV
Current Consumption	I _{SS}	6.4V	No load	-	2.0	3.0	μA
Line Regulation	$\frac{\Delta V_{OUT}}{\Delta V_{IN} \times V_{OUT}}$	-	5.4V ≤ V _{IN} ≤ 12V I _{OUT} =40mA	-	0.2	-	%/V
Input Voltage	V _{IN}	-	-	-	-	15	V
Temperature Coefficient	$\frac{\Delta V_{OUT}}{\Delta T_a}$	6.4V	I _{OUT} =40mA -40°C < T _a < 85°C	-	±0.5	-	mV/°C

Note: Dropout voltage is defined as the input voltage minus the output voltage that produces a 2% change in the output voltage from the value at V_{IN} = V_{OUT}+2V with a fixed load.

H7350-A, +5.0V Output Type

Parameter	Symbol	Test Conditions		Min.	Typ.	Max.	Unit
		V _{IN}	Conditions				
Output Voltage	V _{OUT}	7V	I _{OUT} =40mA	4.900	5.000	5.100	V
Output Current	I _{OUT}	7V	-	-	250	-	mA
Load Regulation	ΔV _{OUT}	7V	1mA ≤ I _{OUT} ≤ 80mA	-	45	90	mV
Voltage Drop(Note)	V _{DIF}	-	I _{OUT} =40mA ΔV _{OUT} =2%	-	80	-	mV
Current Consumption	I _{SS}	7V	No load	-	2.0	3.0	μA
Line Regulation	$\frac{\Delta V_{OUT}}{\Delta V_{IN} \times V_{OUT}}$	-	5.4V ≤ V _{IN} ≤ 12V I _{OUT} =40mA	-	0.2	-	%/V
Input Voltage	V _{IN}	-	-	-	-	15	V
Temperature Coefficient	$\frac{\Delta V_{OUT}}{\Delta T_a}$	7V	I _{OUT} =40mA -40°C < T _a < 85°C	-	±0.5	-	mV/°C

Note: Dropout voltage is defined as the input voltage minus the output voltage that produces a 2% change in the output voltage from the value at V_{IN} = V_{OUT}+2V with a fixed load.

Typical Performance Characteristics

(1) Output Voltage vs Input voltage

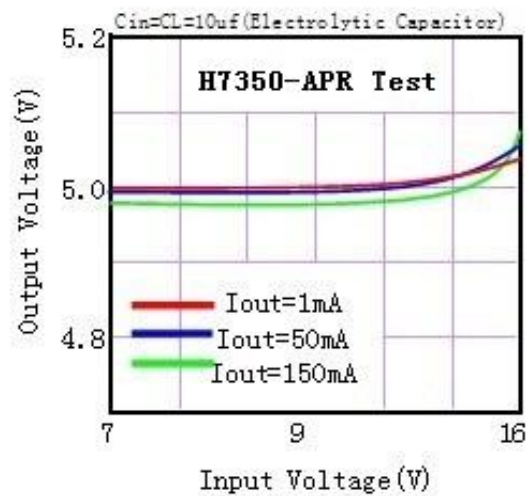
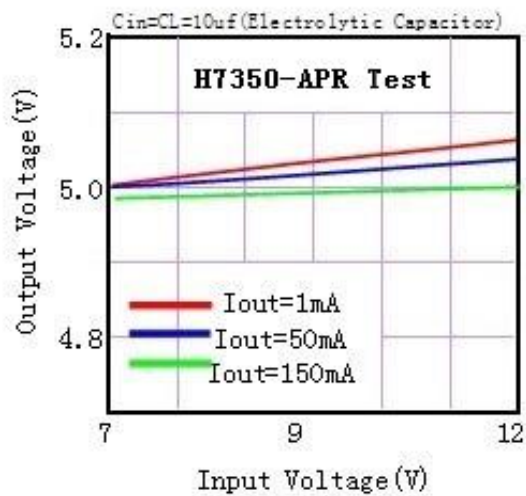
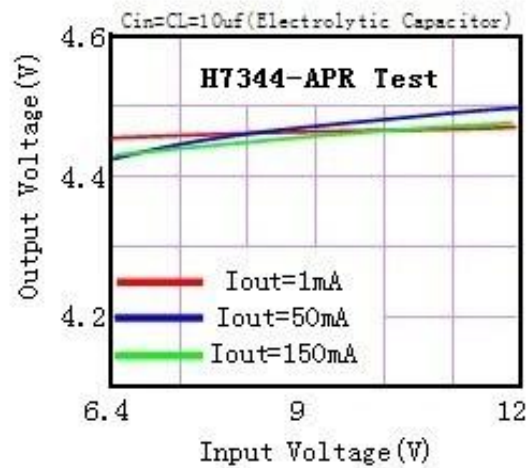
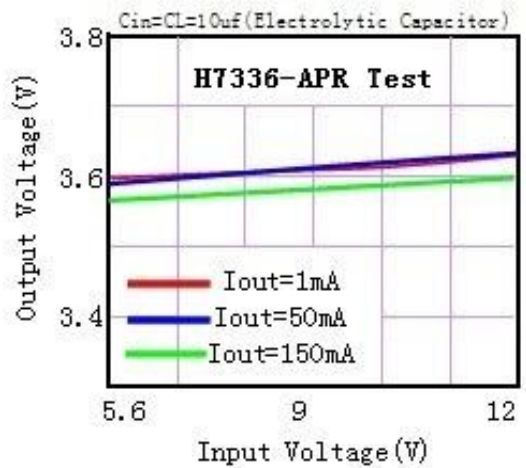
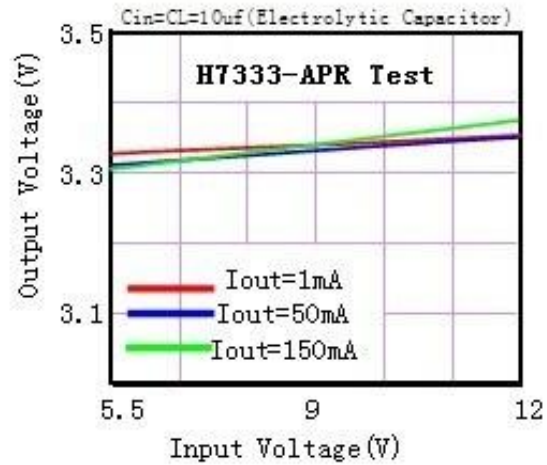
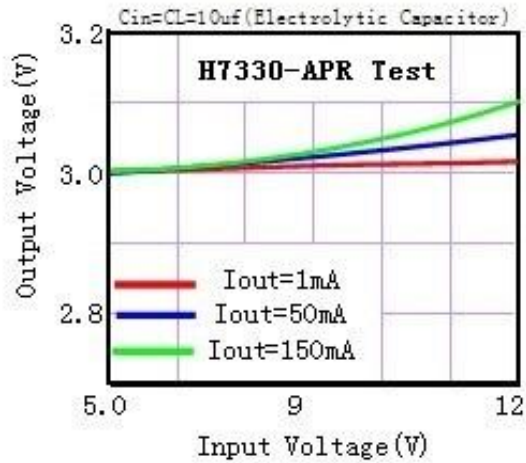

(2) Output Voltage vs. Output Current

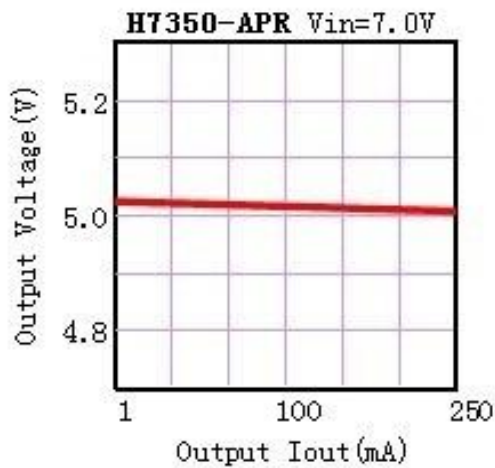
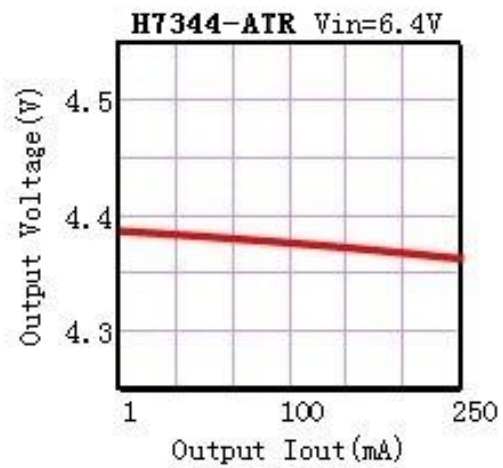
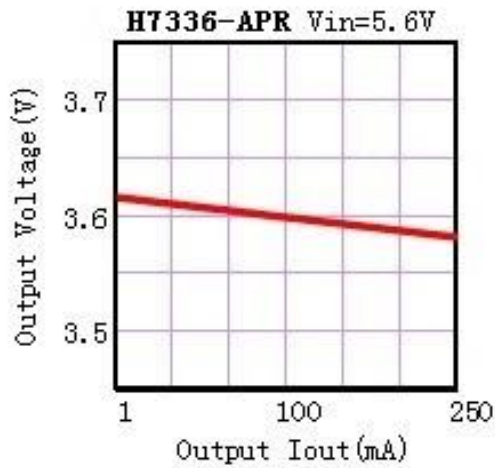
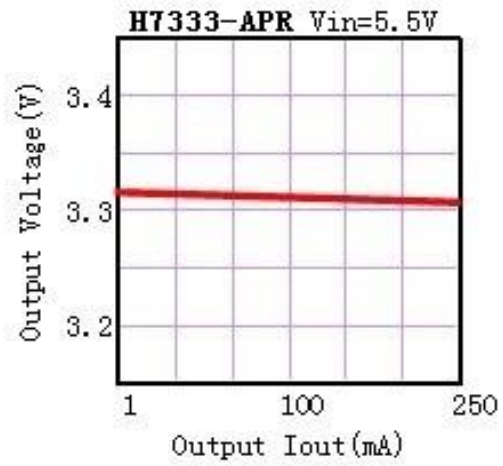
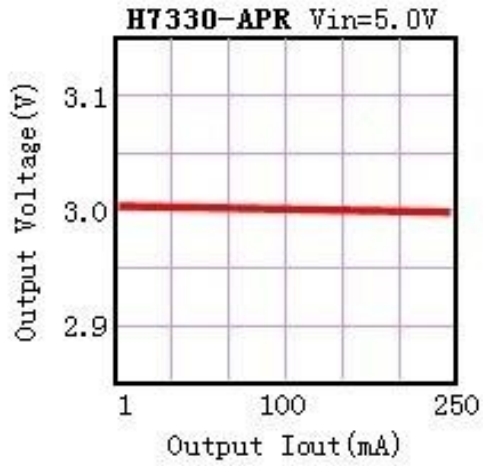

(3) Input Transient Response

H7330-ATR Iout=10mA CL=10uF

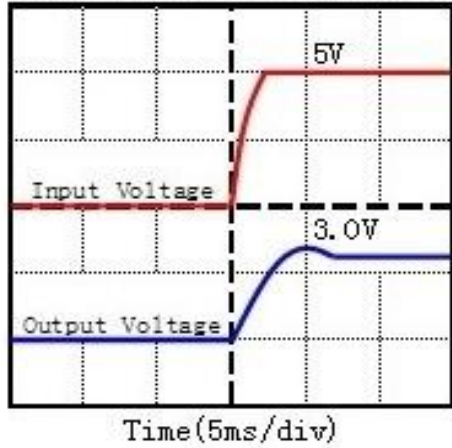

H7333-ATR Iout=10mA CL=10uF

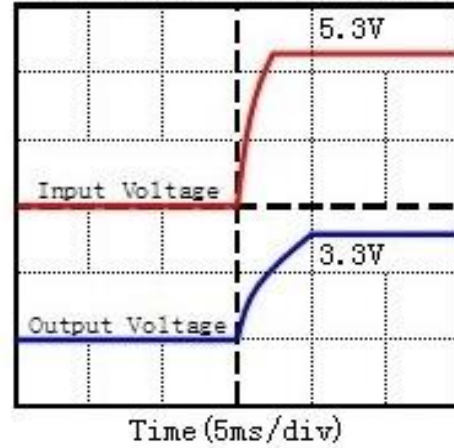

H7344-ATR Iout=10mA CL=10uF

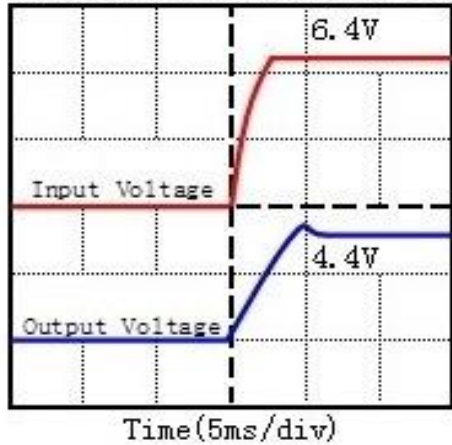

H7350-APR Iout=10mA CL=10uF

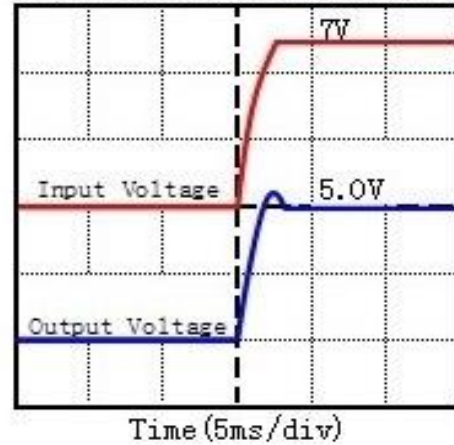

(4) Output Voltage vs. Ambient Temperature

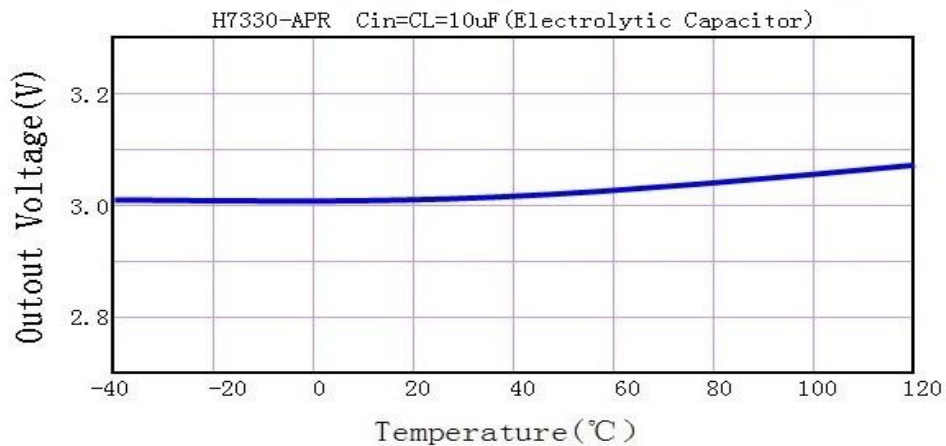

(5) MAX Output Current Vs. Input Voltage

H7330-APR

Input Voltage	Max Output Current
5V	250mA
9V	200mA
12V	150mA
15V	100mA

H7333-APR

Input Voltage	Max Output Current
5.3V	250mA
9V	200mA
12V	150mA
15V	100mA

H7350-APR

Input Voltage	Max Output Current
7V	250mA
9V	200mA
12V	150mA
15V	100mA

Application Circuits

Basic Circuits

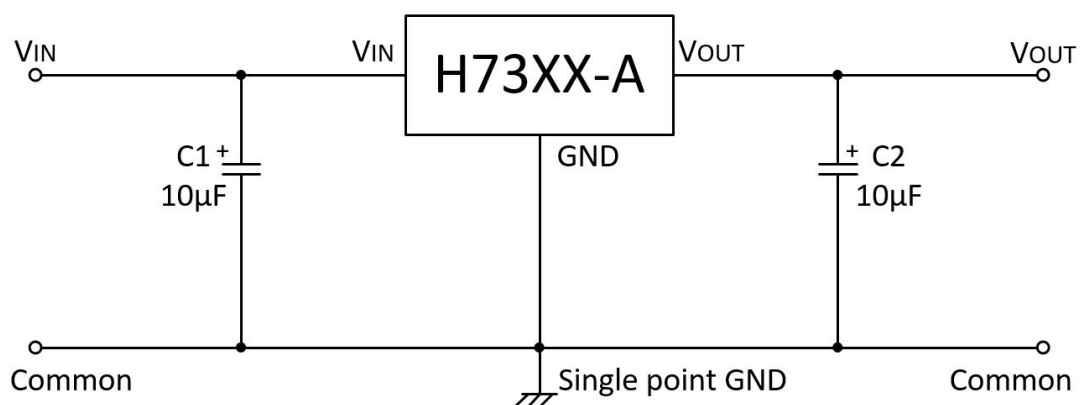

Package Information (T092)

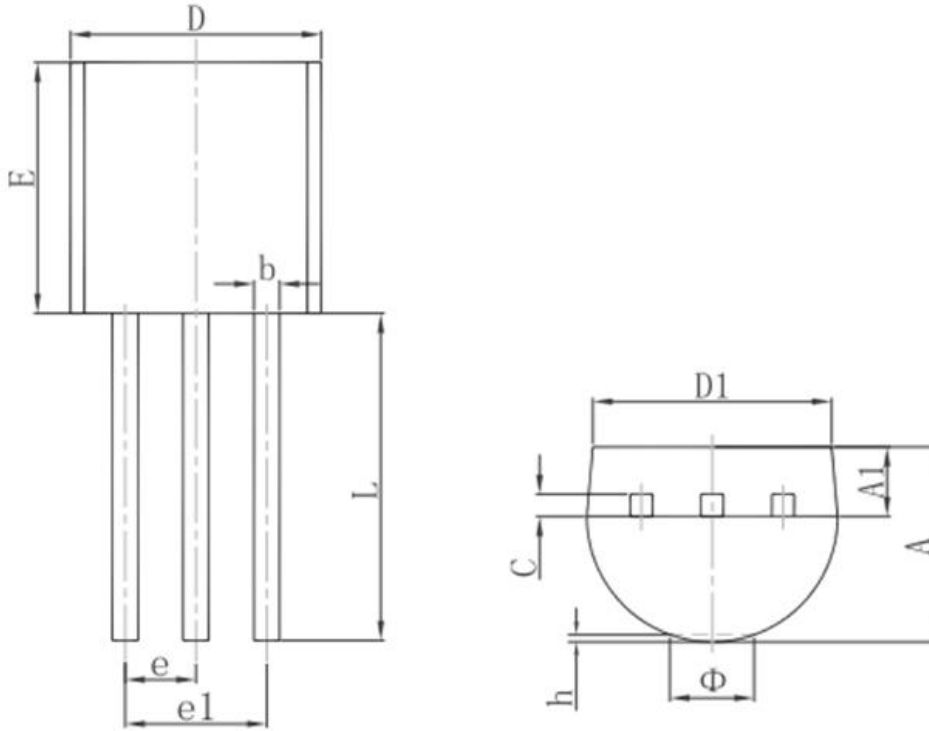

Symbol	Dimensions In Millimeters		Dimensions In Inches	
	Min.	Max.	Min.	Max.
A	3.300	3.700	0.130	0.146
A1	1.100	1.400	0.043	0.055
b	0.380	0.550	0.015	0.022
c	0.360	0.510	0.014	0.020
D	4.300	4.700	0.169	0.185
D1	3.430		0.135	
E	4.300	4.700	0.169	0.185
e	1.270TYP.		0.050TYP.	
e1	2.440	2.640	0.096	0.104
L	14.100	14.500	0.555	0.571
Φ		1.600		0.063
h	0.000	0.380	0.000	0.015

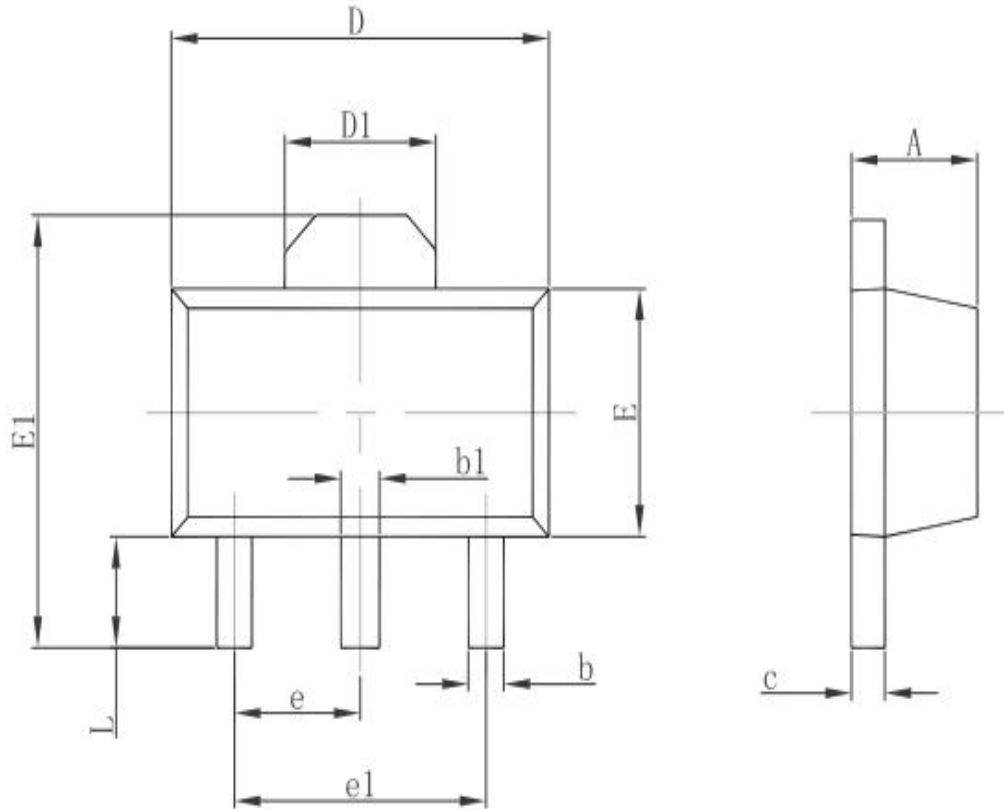
Package Information (SOT89)

Symbol	Dimensions In Millimeters		Dimensions In Inches	
	Min.	Max.	Min.	Max.
A	1.400	1.600	0.055	0.063
b	0.320	0.520	0.013	0.020
b1	0.400	0.580	0.016	0.023
c	0.350	0.440	0.014	0.017
D	4.400	4.600	0.173	0.181
D1	1.550REF.		0.061REF.	
E	2.300	2.600	0.091	0.102
E1	3.940	4.250	0.155	0.167
e	1.500TYP.		0.060TYP.	
e1	3.000TYP.		0.118TYP.	
L	0.900	1.200	0.035	0.047

Package Information (SOT23)

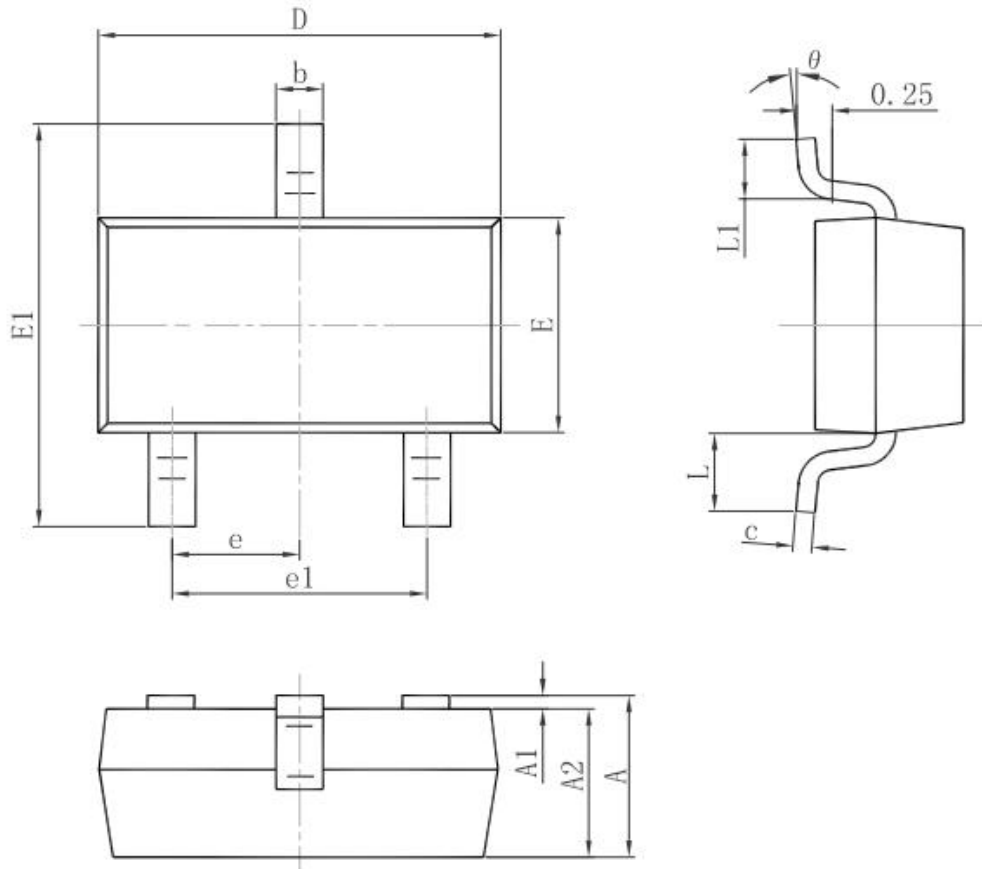

Symbol	Dimensions In Millimeters		Dimensions In Inches	
	Min.	Max.	Min.	Max.
A	0.900	1.150	0.035	0.045
A1	0.000	0.100	0.000	0.004
A2	0.900	1.050	0.035	0.041
b	0.300	0.500	0.012	0.020
c	0.080	0.150	0.003	0.006
D	2.800	3.000	0.110	0.118
E	1.200	1.400	0.047	0.055
E1	2.250	2.550	0.089	0.100
e	0.950TYP.		0.037TYP.	
e1	1.800	2.000	0.071	0.079
L	0.550REF.		0.022REF.	
L1	0.300	0.500	0.012	0.020
θ	0°	8°	0°	8°

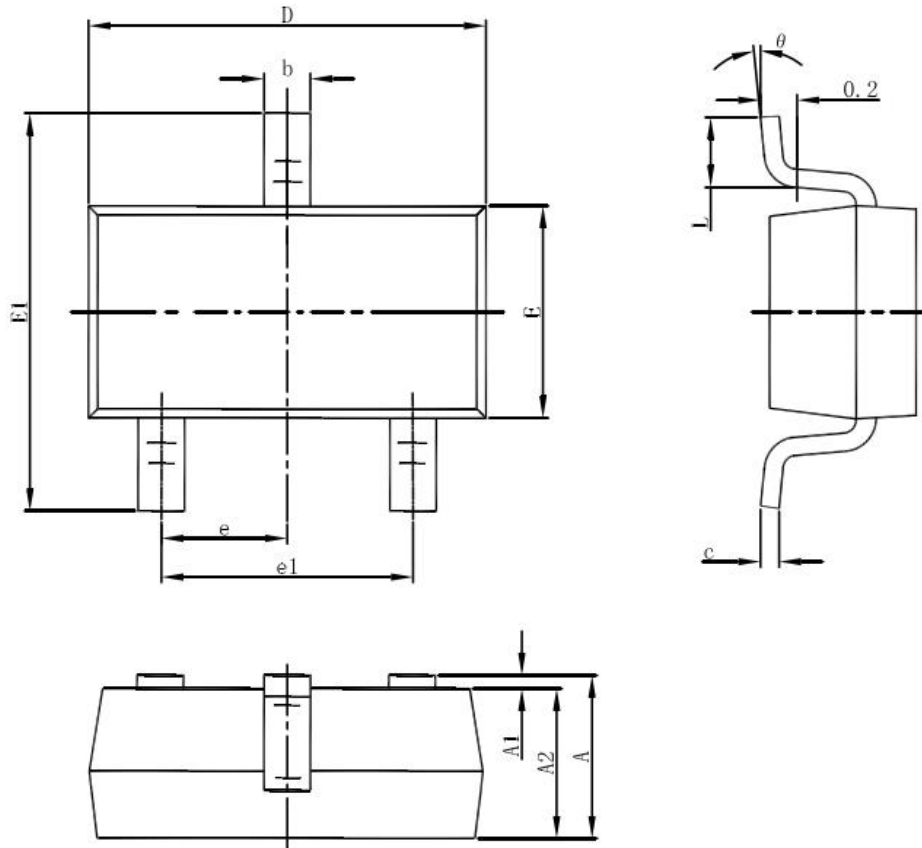
Package Information (SOT23-3)

Symbol	Dimensions In Millimeters		Dimensions In Inches	
	Min.	Max.	Min.	Max.
A	1.050	1.250	0.041	0.049
A1	0.000	0.100	0.000	0.004
A2	1.050	1.150	0.041	0.045
b	0.300	0.500	0.012	0.020
c	0.100	0.200	0.004	0.008
D	2.820	3.020	0.111	0.119
E	1.500	1.700	0.059	0.067
E1	2.650	2.950	0.104	0.116
e	0.950(BSC)		0.037(BSC)	
e1	1.800	2.000	0.071	0.079
L	0.300	0.600	0.012	0.024
θ	0°	8°	0°	8°

Special Instructions

The company reserves the right of final interpretation of this specification.

Version Change Description

Version: V2.0

Author: Yangyang

Time: 2021.10.19

Modify the record:

1. Re-typesetting the manual and checking some data
-