

80V , 1A , 480KHz DCDC, Step-Down Converter

SSP9481

General Description

The SSP9481 is a monolithic, step-down, switch-mode converter with a built-in power MOSFET. Current-mode operation provides a fast transient response and eases loop stabilization.

The wide input Voltage range (4.5V to 80V) provides high efficiency output of 1A current. Low shutdown mode quiescent current of 0.1 μ A is suitable for battery-powered applications.

Fail-state protection includes cycle-by-cycle current-limiting protection and thermal shutdown protection.

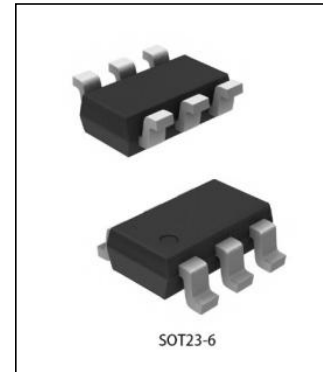

Features

- Output 1A persistent current, 1.5A peak current
- Input Voltage Range: 4.5~80V
- 1 Ω internal power MOSFET
- 480KHz fixed switching frequency
- Stable with Low-ESR Ceramic Output Capacitors
- Cycle-by-cycle current-limiting protection
- Thermal shutdown protection
- >92% efficiency
- Output from 1V to 0.95 \times V_{in} adjustable
- Low shutdown mode current: <1 μ A
- SOT23-6 package

Applications

- High voltage power conversion
- Automotive System
- Industrial power system
- Distributed power system
- Battery powered system

Order specification

Part No	Package	Manner of Packing	Devices per bag/reel
SSP9481	SOT23-6	Reel	3000

Block Diagram and Pin Arrangement Diagram

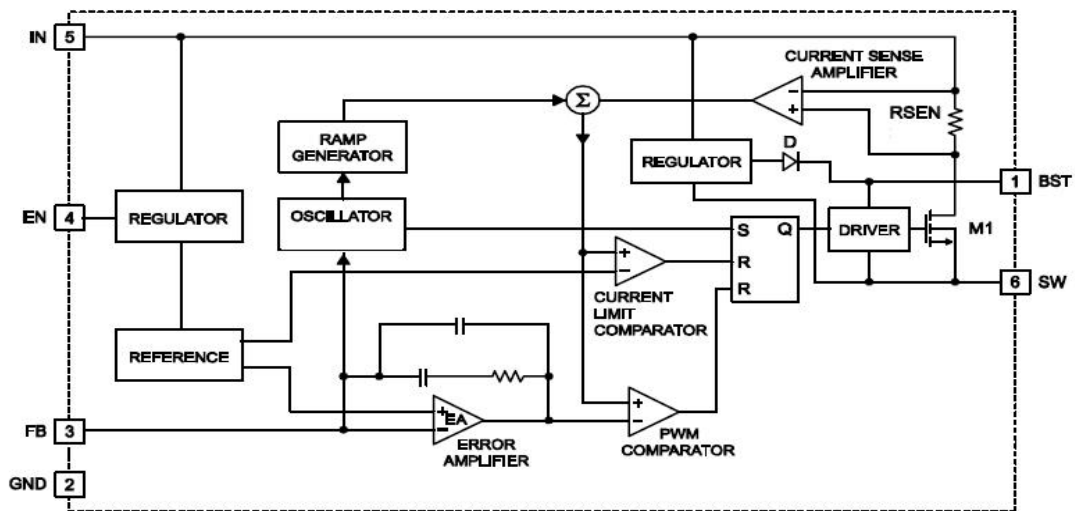

Pin Assignment

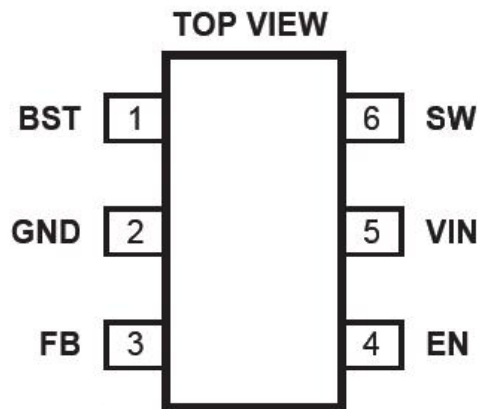

SOT23-6

Pin No.	Pin Name	Description
1	BST	Bootstrap. This is the positive power supply for the internal floating high side MOSFET driver. Connect a bypass capacitor between this pin and SW pin.
2	GND	Ground. It should be connected as close as possible to the output capacitor, avoid high current switching paths.

3	FB	Feedback. This is the input to the error amplifier. Set the output voltage. When the load is short circuited and the FB voltage is below 250mV, the foldback circuit will reduce the oscillation frequency to ensure reliable current limiting protection.
4	EN	Enable input. Pull this pin below the specified threshold to disable. Pull it above the specified threshold to enable. Connect 100K resistor to IN, it can be turned on automatically.
5	VIN	Input Supply. All internal control circuits are powered, including switching tubes. A decoupling capacitor to ground is required close to this pin to reduce switching spikes.
6	SW	Switch node. A low VF Schottky diode to ground is required close to this pin to reduce switching spikes.

Absolute Maximum Ratings

Parameter	Range
Supply Voltage (V_{IN})	-0.3V~85V
Switch Voltage (V_{SW})	-0.3V~ $V_{IN}(MAX)+0.3V$
BST to SW	-0.3V~6.0V
All Other Pins	-0.3V~6.0V
Continuous Power($T_A=+25^{\circ}C$)	0.568W
Junction Temperature	150°C
Lead Temperature	260°C
Storage Temperature	-65°C~150°C
Operating Junction Temp (T_J)	-40°C~125°C
Junction-to-Ambient Thermal Resistance (θ_{JA})	220°C/W
Junction-to-Case Thermal Resistance (θ_{JC})	110°C/W

Recommended Operating Conditions

Parameter	Range
Supply Voltage (V_{IN})	4.5V ~ 80V
Switch Voltage (V_{SW})	1V ~ 0.95* V_{IN}

Electrical Characteristics

$V_{in}=12V$, $T_a=25^{\circ}C$, unless specified otherwise.

Parameter	Symbol	Test Conditions	Min	Typ	Max	Unit
Feedback Voltage	Vfb	$4.5 < V_{in} < 80V$	0.792	0.812	0.832	V
Upper Switch ON Resistance	Rsw	$V_{bst}-V_{sw}=5V$		1		Ω
Upper Switch Leakage	Iswleak	$V_{en}=0V, V_{sw}=0V$			1	μA
Limiting Current	Ilim		1.0	1.25	1.5	A
Oscillator Frequency	Fosc		380	480	580	KHz
Foldback Frequency	Fsw-f	Vfb=0V		150		KHz
UVLO Up Threshold	Vuvlo-r		2.9	3.3	3.73	V
UVLO Hysteresis	Vuvlo-f		2.65	3.05	3.45	V
Minimum Switch ON Time	Ton min			100		ns
Enable Threshold Voltage	Venr		1.35			V
Enable Turn-off Voltage	Venf				1.0	V
EN Input Current	Ien	$V_{en}=2V$		3		μA
		$V_{en}=0V$		0.1		μA
Quiescent Current	Isq	$V_{en}=2V, V_{fb}=1V$		0.73	0.86	mA
Shutdown Current	Isd	$V_{en}=0V$		0.1	1.0	μA
Thermal Shutdown	Temp			240		$^{\circ}C$

Detailed Description

The SSP9481 is a 480KHz, current mode step-down switching regulator with integrated internal high voltage power MOSFET. The circuit internal error amplifier output is proportional to the peak inductance current, the feedback signal is compared with the internal reference voltage of 0.812V, stable output voltage. It features wide input voltage range, and precision current limit. Low operational quiescent current feature is suitable for battery powered applications.

Application Circuits

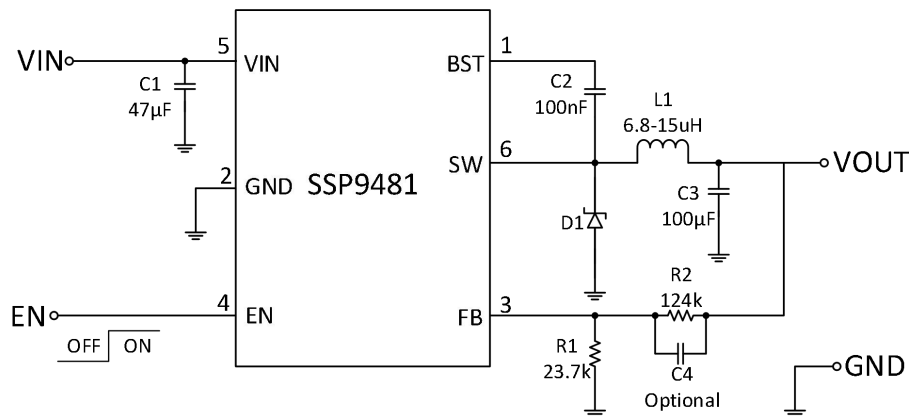

5V output typical application circuit

PCB Layout Guidelines:

PCB layout is very important for the circuit to achieve stable operation. The following suggestions are for your reference:

1. Switching current path as short as possible, input capacitance, high-side MOSFET and external high-speed switching Schottky diode formed loop area as small as possible.
2. Bypass ceramic capacitor is placed near the VIN end. SW output routing should be as short and thick as possible.
3. All feedback circuit connections should be short and direct, with feedback resistance and compensation elements as close to the chip as possible.
4. SW route should be far away from sensitive simulated areas, such as FB.
5. SW, VIN, and especially ground should be connected to a large copper-clad area to cool the chip, improve thermal performance, and enhance long-term reliability.

Select components

Setting the Output Voltage

The output voltage is set using a resistive voltage divider from the output voltage to FB pin.

$$V_{FB} = V_{OUT} \times R2 / (R1 + R2)$$

Typical voltage of VFB is 0.812V.

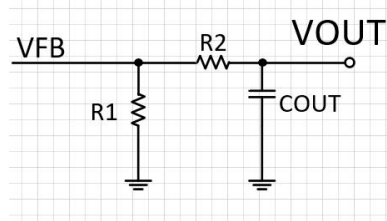

Reference resistance for each output voltage:

Vout (V)	R1(KΩ)	R2(KΩ)
1.8	64.9 (1%)	80.6 (1%)
2.5	23.7 (1%)	49.9 (1%)
3.3	16.2 (1%)	49.9 (1%)
5	23.7 (1%)	124 (1%)

Inductor

The inductor is required to supply constant current to the output load. A larger value inductor will result in lower output ripple voltage. Generally, a good rule for determining the inductance to use is to allow the peak-to-peak ripple current in the inductor to be approximately 30% of the maximum load current. Also, make sure that the peak inductor current is below the maximum switch current limit, it will not saturate at the maximum inductance peak.

$$L = \frac{V_{out} \times (V_{in} - V_{out})}{V_{in} \times \Delta I_L \times f_{OSC}}$$

Where ΔI_L is inductance ripple current. If the maximum load current is 2A, the inductor ripple current is selected to be about 30%. The maximum peak inductance current is:

$$I_{L(MAX)} = I_{LOAD} + \frac{\Delta I_L}{2}$$

Under light load conditions up to 100mA, larger inductors are recommended to improve efficiency.

Input Capacitor

The input capacitor can be electrolytic, tantalum or ceramic. When using electrolytic or tantalum capacitors, a small, high quality ceramic capacitor, i.e. 0.1μF, should be placed as close to the IC as possible. When using ceramic capacitors, make sure they have sufficient capacitance values to prevent input from excessive voltage ripple.

Output Capacitor

The output capacitor is used to maintain the DC output voltage. Low ESR electrolytic capacitors are recommended to keep the output voltage ripple low. The characteristics of the output capacitor will affect the stability of the voltage stabilizer system.

Catch Diode

When the upper MOSFET is off, the output diode is inductance current freewheeling. Use Schottky diodes to reduce the loss caused by the diode's forward guide on voltage and reverse recovery. The average current flowing through the diode can be estimated by the following formula:

$$I_D = I_{OUT} \times \left(1 - \frac{V_{OUT}}{V_{IN}} \right)$$

When selecting the diode, the rated voltage should be greater than the maximum input voltage, and the average current of the secondary tube should be greater than the maximum load current.

Enable-control

Pulling the EN pin voltage below the specified threshold will shut down the chip. In off mode, the SSP9481 shutdown current drops to less than 1μA. Pulling the EN pin high will open the chip. Connect the 100K resistor to the Vin pin to automatically start the chip, or you can control the starting voltage through the resistance voltage division.

$$V_{in} \times R_5 / (R_4 + R_5) > V_{enr}$$

V_{enr} is the ascending threshold voltage of EN, the lower limit of which is 1.4V.

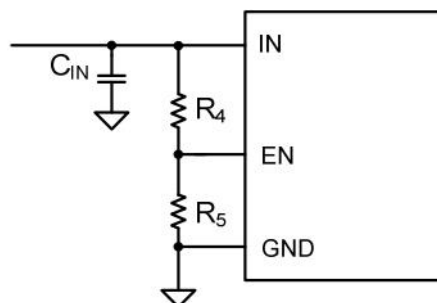

Typical Performance Characteristics

$C_{in} = 47\mu F$, $C_{out} = 100\mu F$, $L = 10\mu H$, $T_A = +25^\circ C$, unless specified otherwise.

EN ON
(VIN=12V, VOUT=5V, RLOAD=50Ω,
Time (1ms/div))

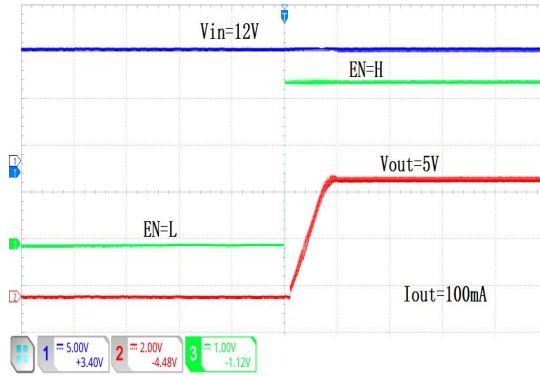

EN OFF
(VIN=12V, VOUT=5V, RLOAD=50Ω,
Time (10ms/div))

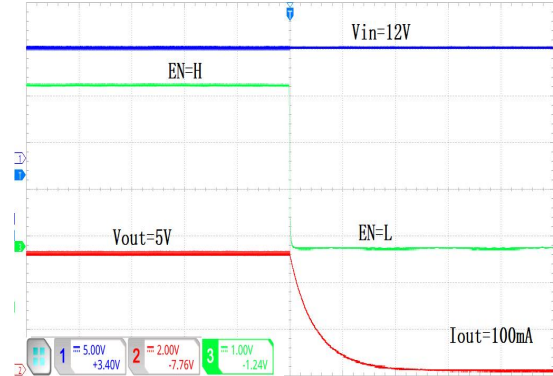

Load Transient Response
(VIN=24V, VOUT=5V, IOU=0~100mA)

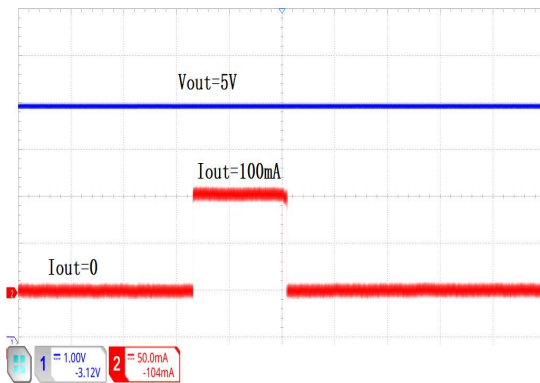

Load Transient Response
(VIN=24V, VOUT=5V, IOU=0~1A)

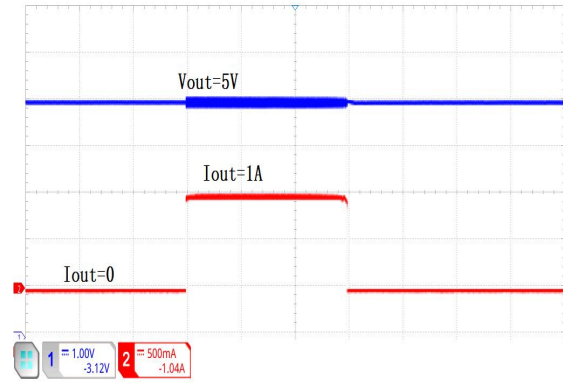

Package Information (SOT23-6)

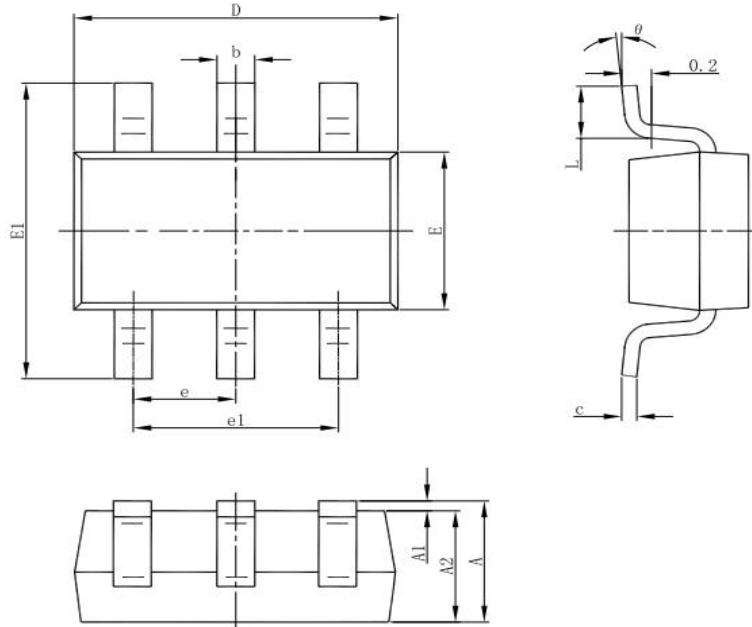

Symbol	Dimensions In Millimeters		Dimensions In Inches	
	Min.	Max.	Min.	Max.
A	1.050	1.250	0.041	0.049
A1	0.000	0.100	0.000	0.004
A2	1.050	1.150	0.041	0.045
b	0.300	0.500	0.012	0.020
c	0.100	0.200	0.004	0.008
D	2.820	3.020	0.111	0.119
E	1.500	1.700	0.059	0.067
E1	2.650	2.950	0.104	0.116
e	0.950(BSC)		0.037(BSC)	
e1	1.800	2.000	0.071	0.079
L	0.300	0.600	0.012	0.024
θ	0°	8°	0°	8°

Special Instructions

The company reserves the right of final interpretation of this specification.

Version Change Description

Version: V1.0

Author: Xinchun Li

Time: 2022.01.08

Modify the record:

1. Editio princeps

Statement

The information in the usage specification is correct at the time of publication, Shanghai Siproin Microelectronics Co. has the right to change and interpret the specification, and reserves the right to modify the product without prior notice. Users can obtain the latest version information from our official website or other effective channels before confirmation, and verify whether the relevant information is complete and up to date.

With any semiconductor product, there is a certain possibility of failure or failure under certain conditions. The buyer is responsible for complying with safety standards and taking safety measures when using the product for system design and complete machine manufacturing. The product is not authorized to be used as a critical component in life-saving or life-sustaining products or systems, in order to avoid potential failure risks that may cause personal injury or property loss.