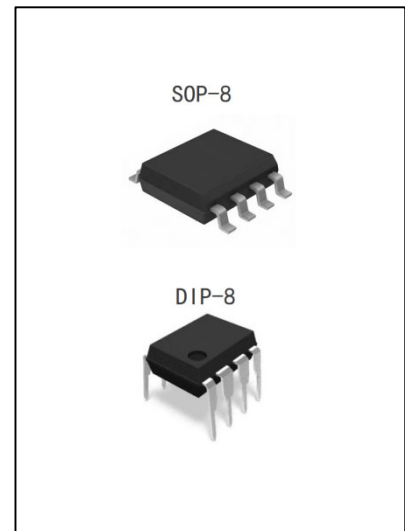

+15kV ESD Protected 2Mbps Data Rate RS-485**MAX13085****General Description**

The MAX13085 is a half-duplex high speed transceiver for RS-485 and RS422 communication. IC contains one driver and one receiver.

The MAX13085 has a fail-safe circuit. It has a slew-rate-limited driver that reduces EMI and reflection due to improperly matched terminal cables, and achieves error-free data transmission of up to 2Mbps. Each driver output and receiver input is protected against $\pm 15\text{kV}$ electrostatic discharge (HBM) (ESD) shocks.

The MAX13085 receiver has $1/8$ unit load input impedance, allows up to 256 devices can be attached to the bus. Mainly used in RS-485/RS-422 communication system.

**Features**

- I/O pin ESD protection: +15kV HBM
Other pins have level 3 ESD protection: >+8kV HBM
- Fractional unit load allows up to 256 devices on the bus
- + 5V operating voltage (For + 3.3v power supply, recommend the maximum transmission rate is 500Kbps)
- Data transmission up to 2Mbps
- Low current shutdown mode operating current: 1nA
- Current limiting and thermal turn-off function can be used for driver overload protection
- SOP8 and DIP8 package

Applications

- Intelligent instrument
- Industrial process control
- Building automation network
- Motor control
- EMI sensitive transceiver application

Order specification

Part No	Package	Manner of Packing	Devices per bag/reel
MAX13085	SOP8	Reel	2500

Block Diagram and Pin Arrangement Diagram

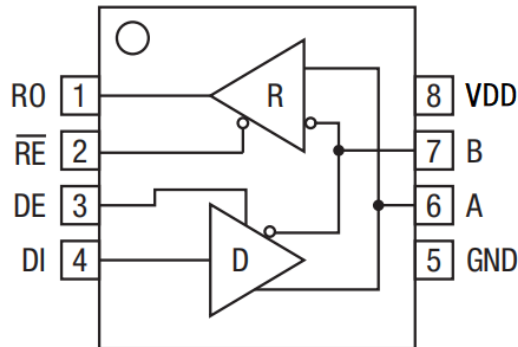

Pin Assignment

Pin No.	Pin Name	Description	I/O
1	RO	Receiver output: If $A-B \geq -0.05V$, RO will be high; If $A-B \leq -0.2V$, RO will be low; If A and B are open or shorted, RO will be high.	O
2	\overline{RE}	Receiver output enable: RO is enabled when \overline{RE} is low; RO is high impedance when \overline{RE} is high.	I
3	DE	Driver output enable: The driver outputs, A and B are enabled by bringing DE high. They are high impedance when DE is low.	I
4	DI	Driver input: A low on DI forces output A low and output B high. Similarly, a high on DI forces output A high and output B low.	I
5	GND	Ground	
6	A	Receiver input and driver output	I/O
7	B	Receiver input and driver output	I/O
8	VDD	Supply voltage	

Functional Description

The MAX13085 is a half-duplex high speed transceiver for RS-485 and RS422 communication. IC contains one driver and one receiver. The MAX13085 receiver has 1/8 unit load input impedance, allows up to 256 devices can be attached to the bus.

Receiver Truth Table

Input			Output
\overline{RE}	DE	A - B	RO
L	X	$\geq -0.05V$	H
L	X	$\leq -0.2V$	L
L	X	Open/shorted	H
H	H	X	Z
H	L	X	Z

Driver Truth Table

Input			Output	
\overline{RE}	DE	DI	B	A
X	H	H	L	H
X	H	L	H	L
L	L	X	Z	Z
H	L	X	Z	

Absolute Maximum Ratings

Unless specified otherwise, $T_{amb} = 25^{\circ}C$

Parameter	Symbol	Value	Unit
Supply Voltage	V_{DD}	-0.3~7	V
Input / Output Voltage	V_{IN}/V_{OUT}	GND-0.3~ $V_{DD}+0.3$	V
A/B Input / Output Voltage	$V_{INA/B}/V_{OUTA/B}$	-13~13	V
Operating Temperature	T_{amb}	-40~85	$^{\circ}C$
Storage Temperature	T	-65~150	$^{\circ}C$

DC Electrical Characteristics

Unless specified otherwise, VDD=5V±5%, Tamb= 25°C

Parameter	Symbol	Test Conditions	Min	Typ	Max	Unit
Driver						
Differential driver output	V _{OD1}	No load			5	V
Differential driver output	V _{OD2}	R=50Ω (RS-422) ⁽¹⁾	2.0			V
		R=27Ω (RS-485) ⁽¹⁾	1.5			V
Change in magnitude of driver differential output voltage for complementary output states	ΔV _{OD}	R=50Ω or 27Ω ⁽¹⁾		0.01	0.2	V
Driver common-mode output voltage	V _{OC}	R=50Ω or 27Ω ⁽¹⁾			3	V
Change in magnitude of driver common-mode output voltage for complementary output states	ΔV _{OC}	R=50Ω or 27Ω ⁽¹⁾		0.01	0.2	V
Input high voltage	V _{IH1}	DE, \overline{RE} , DI	2.0			V
Input low voltage	V _{IL1}	DE, \overline{RE} , DI			0.8	V
Input current	I _{IN1}	DE, \overline{RE} , DI	-2		2	μA
Input current (A, B)	I _{IN2}	DE=GND, V _{DD} =GND or 5.25V	V _{in} =12V		125	μA
			V _{in} =-7V		-75	μA
Driver short-circuit current	I _{OD1}	-7V≤V _{OUT} ≤V _{DD}	-250			mA
		0V≤V _{OUT} ≤12V			250	mA
		0V≤V _{OUT} ≤V _{DD}	±25			mA
Receiver						
Differential threshold voltage	V _{TH}	-7V≤V _{CM} ≤12V	-200	-125	-50	mV
input hysteresis voltage	ΔV _{TH}			25		mV
output high voltage	V _{OH}	I _O =-4mA, V _{ID} =-50mV	3.5			V
output low voltage	V _{OL}	I _O =4mA, V _{ID} =-200mV			0.4	V
3-state(high impedance) output current at receiver	I _{OZR}	0.4V≤V _O ≤2.4V			±1	μA
input resistance	R _{IN}	-7V≤V _{CM} ≤12V	96			kΩ
Receiver short-circuit current	I _{OSR}	0V≤V _{RO} ≤V _{DD}	±7		±95	mA
Supply Current	I _{CC}	No load, \overline{RE} =DI -GND		430	900	μA

		DE=GND	375	600	μA
Supply Current in Shutdown	I _{SHDN}	DE=GND, $\overline{RE}=V_{DD}$	0.00 1	10	μA
ESD Protection (A/B)	ESD	Human Body Model	±15		kV

Transmission characteristics

Unless specified otherwise, VDD=5V±5%, Tamb= 25°C

Parameter	Symbol	Test Conditions	Min.	Typ.	Max.	Unit
slew-rate-limited						
Driver Input to Output	t _{DPLH}	R _{DIFF} =54Ω, C _{L1} =C _{L2} =100pF ⁽²⁾	250	720	1000	ns
Driver Input to Output	t _{DPHL}	R _{DIFF} =54Ω, C _{L1} =C _{L2} =100pF ⁽²⁾	250	720	1000	ns
t _{DPLH} -t _{DPHL}	t _{DSKEW}	R _{DIFF} =54Ω, C _{L1} =C _{L2} =100pF ⁽²⁾		-3	±100	ns
Driver Rise or Fall Time	t _{DR} ,t _{DF}	R _{DIFF} =54Ω, C _{L1} =C _{L2} =100pF ⁽²⁾	200	530	750	ns
Maximum Data Rate	f _{MAX}			2000		kbps
Driver Enable to Output High	t _{DZH}	C _L =100pF, S2 closed ⁽³⁾			2500	ns
Driver Enable to Output Low	t _{DZL}	C _L =100pF, S1 closed ⁽³⁾			2500	ns
Driver Disable Time from Low	t _{DLZ}	C _L =15pF, S1 closed ⁽³⁾			100	ns
Driver Disable Time from High	t _{DHZ}	C _L =15pF, S2 closed ⁽³⁾			100	ns
Receiver Input to Output	t _{RPLH}	V _{ID} ≥2.0V		127	200	ns
Receiver Input to Output	t _{RPHL}	Rise or Fall Time≤15ns ⁽⁴⁾		127	200	ns
t _{RPLH} -t _{RPHL}	t _{RSKD}	V _{ID} ≥2.0V Rise or Fall Time≤15ns ⁽⁴⁾		3	±30	ns
Receiver Enable to Output Low	t _{RZL}	C _L =100pF, S1 closed ⁽⁵⁾		20	50	ns
Receiver Enable to Output High	t _{RZH}	C _L =100pF, S2 closed ⁽⁵⁾		20	50	ns
Receiver Disable Time from Low	t _{RLZ}	C _L =100pF, S1 closed ⁽⁵⁾		20	50	ns
Receiver Disable Time from High	t _{RHZ}	C _L =100pF, S2 closed ⁽⁵⁾		20	50	ns
Time to Shutdown	t _{SHDN}		50	200	600	ns

Driver Enable from Shutdown to Output High	$t_{DZH(SHDN)}$	$C_L=15pF$, S2 closed ⁽³⁾			4500	ns
Driver Enable from Shutdown to Output Low	$t_{DZL(SHDN)}$	$C_L=15pF$, S1 closed ⁽³⁾			4500	ns
Receiver Enable from Shutdown to Output High	$t_{RZH(SHDN)}$	$C_L=100pF$, S2 closed ⁽³⁾			3500	ns
Receiver Enable from Shutdown to Output Low	$t_{RZL(SHDN)}$	$C_L=100pF$, S1 closed ⁽³⁾			3500	ns
No slew-rate-limited						
Driver Input to Output	t_{DPLH}	$R_{DIFF}=54\Omega$, $C_{L1}=C_{L2}=100pF^{(2)}$		34	60	ns
Driver Input to Output	t_{DPHL}	$R_{DIFF}=54\Omega$, $C_{L1}=C_{L2}=100pF^{(2)}$		34	60	ns
$ t_{DPLH}-t_{DPHL} $	t_{DSKEW}	$R_{DIFF}=54\Omega$, $C_{L1}=C_{L2}=100pF^{(2)}$		-2.5	± 10	ns
Driver Rise or Fall Time	t_{DR}, t_{DF}	$R_{DIFF}=54\Omega$, $C_{L1}=C_{L2}=100pF^{(2)}$		14	25	ns
Maximum Data Rate	f_{MAX}		10			Mbps
Driver Enable to Output High	t_{DZH}	$C_L=100pF$, S2 closed ⁽³⁾			150	ns
Driver Enable to Output Low	t_{DZL}	$C_L=100pF$, S1 closed ⁽³⁾			150	ns
Driver Disable Time from Low	t_{DLZ}	$C_L=15pF$, S1 closed ⁽³⁾			100	ns
Driver Disable Time from High	t_{DHZ}	$C_L=15pF$, S2 closed ⁽³⁾			100	ns
Receiver Input to Output	t_{RPLH}	$ V_{ID} \geq 2.0V$ Rise or Fall Time $\leq 15ns^{(4)}$		106	150	ns
Receiver Input to Output	t_{RPHL}			106	150	ns
$ t_{RPLH}-t_{RPHL} $	t_{RSKD}	$ V_{ID} \geq 2.0V$ Rise or Fall Time $\leq 15ns^{(4)}$		0	± 10	ns
Receiver Enable to Output Low	t_{RZL}	$C_L=100pF$, S1 closed ⁽⁵⁾		20	50	ns
Receiver Enable to Output High	t_{RZH}	$C_L=100pF$, S2 closed ⁽⁵⁾		20	50	ns
Receiver Disable Time from Low	t_{RLZ}	$C_L=100pF$, S1 closed ⁽⁵⁾		20	50	ns
Receiver Disable Time from High	t_{RHZ}	$C_L=100pF$, S2 closed ⁽⁵⁾		20	50	ns
Time to Shutdown	t_{SHDN}		50	200	600	ns

Driver Enable from Shutdown to Output High	$t_{DZH(SHDN)}$	$C_L=15pF$, S2 closed ⁽³⁾			250	ns
Driver Enable from Shutdown to Output Low	$t_{DZL(SHDN)}$	$C_L=15pF$, S1 closed ⁽³⁾			250	ns
Receiver Enable from Shutdown to Output High	$t_{RZH(SHDN)}$	$C_L=100pF$, S2 closed ⁽³⁾			3500	ns
Receiver Enable from Shutdown to Output Low	$t_{RZL(SHDN)}$	$C_L=100pF$, S1 closed ⁽³⁾			3500	ns

Note:

- (1) Test circuit is shown in Figure 1
- (2) Test circuit is shown in Figure 2
- (3) Test circuit is shown in Figure 3
- (4) Test circuit is shown in Figure 4
- (5) Test circuit is shown in Figure 5

Test Circuit

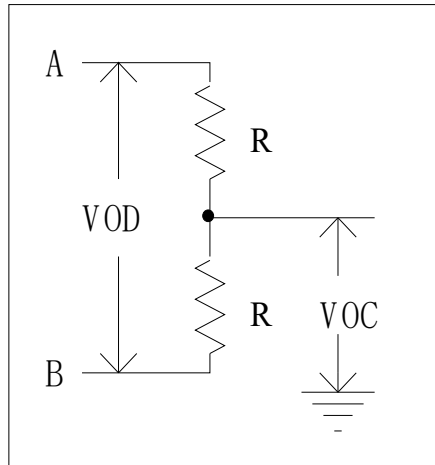

Figure 1 Driver DC Test Circuit

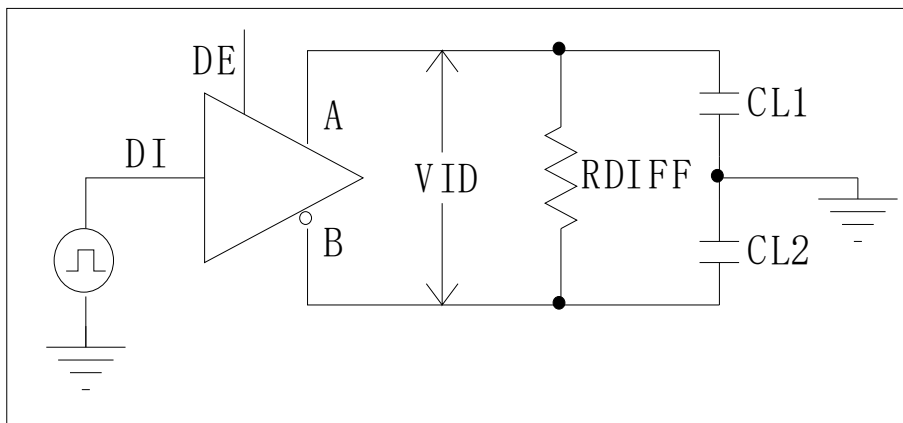

Figure 2 Driver Timing Test Circuit

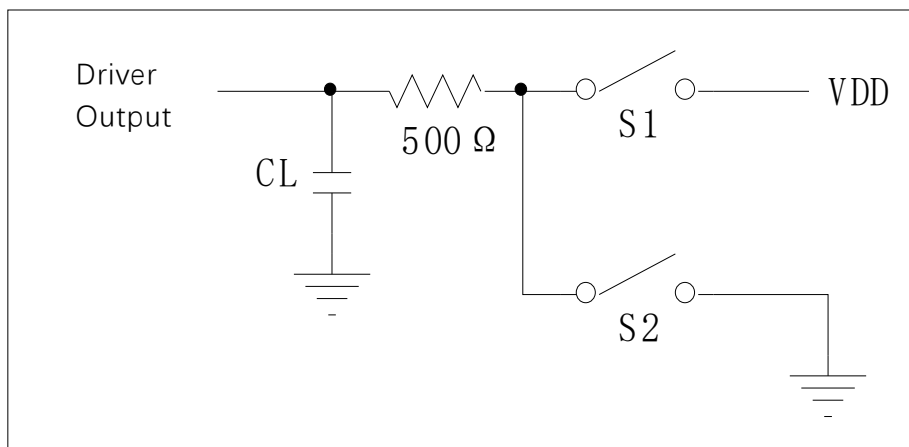

Figure 3 Driver Enable/Invalid Timing Test Circuit

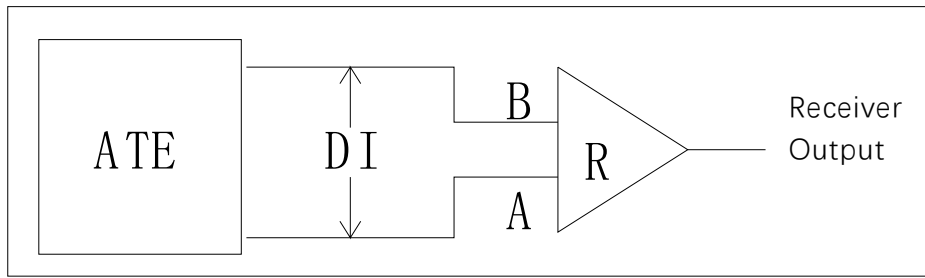

Figure 4 Receiver Propagation Delay Test Circuit

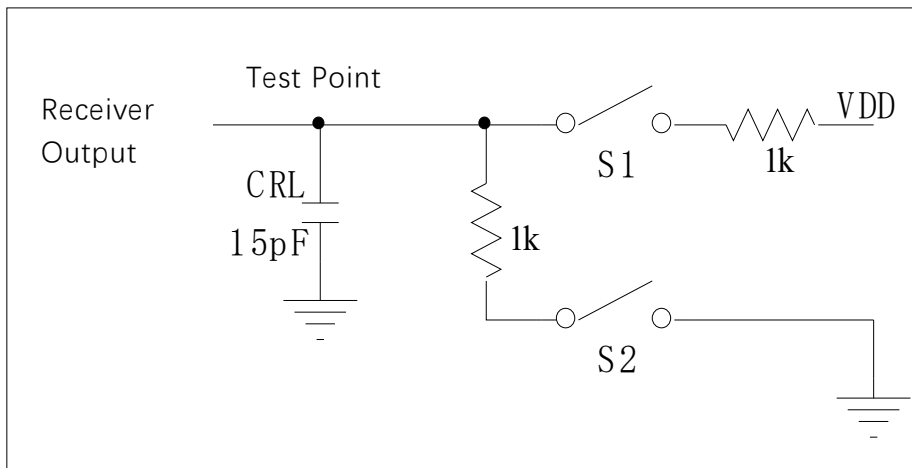

Figure 5 Receiver Enable/Invalid Timing Test Circuit

Application Circuits

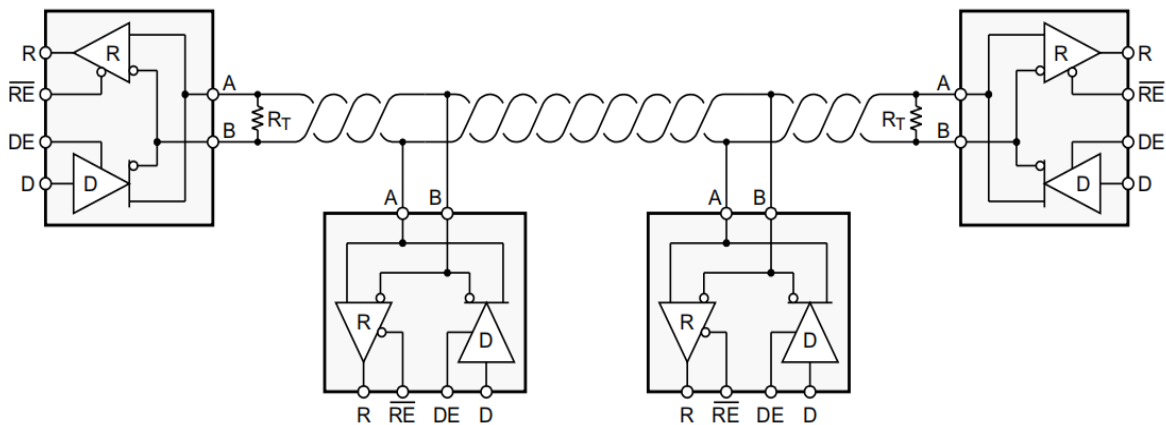
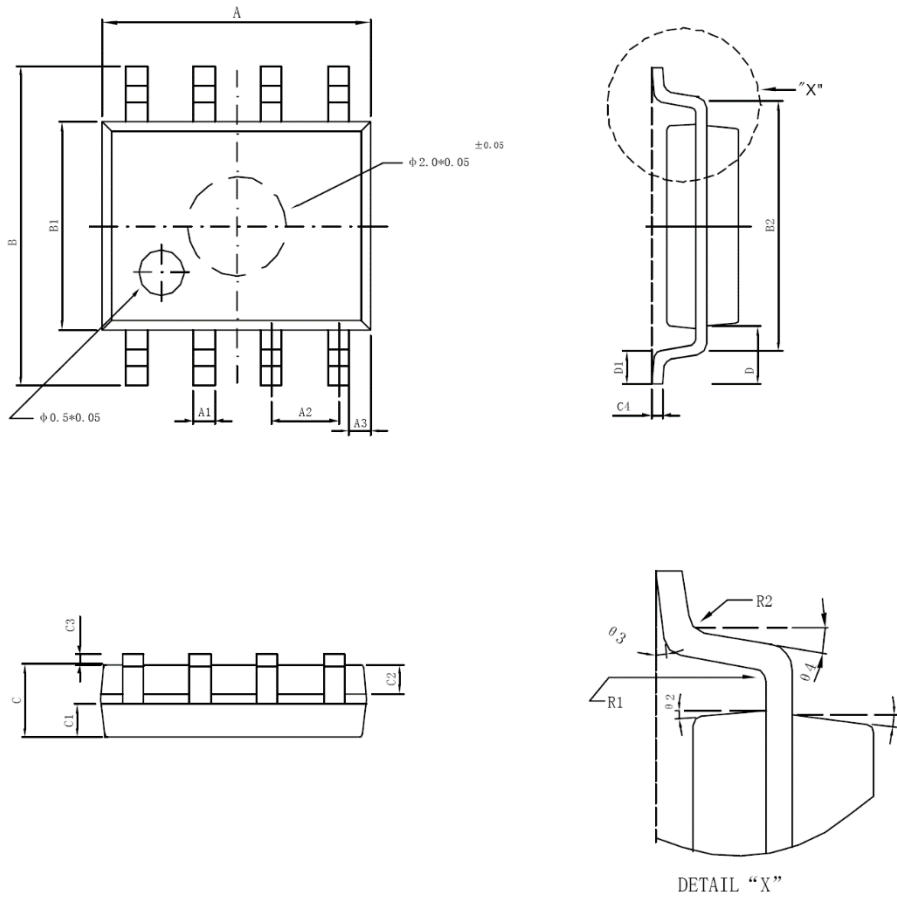

Figure 6 Typical Application Chart

Transceivers are designed for bidirectional data communication over multi-point bus transmission lines. Figure 6 shows a typical network application circuit. These devices can also be used as linear transponders with cable lengths up to 4000 ft. In order to reduce reflection, terminals should be matched with their characteristic impedance at both ends of the transmission line, and the length of the branch line outside the main line should be as short as possible.

Package Information (SOP8)



Symbol	Min. (mm)	Max. (mm)	Symbol	Min. (mm)	Max. (mm)
A	4.95	5.15	C3	0.10	0.20
A1	0.37	0.47	C4	0.20TYP	
A2	1.27TYP		D	1.05TYP	
A3	0.41TYP		D1	0.50TYP	
B	5.80	6.20	R1	0.07TYP	
B1	3.80	4.00	R2	0.07TYP	
B2	5.0TYP		θ1	17°TYP	
C	1.30	1.50	θ2	13°TYP	
C1	0.55	0.65	θ3	4°TYP	
C2	0.55	0.65	θ4	12°TYP	

Package Information (DIP8)

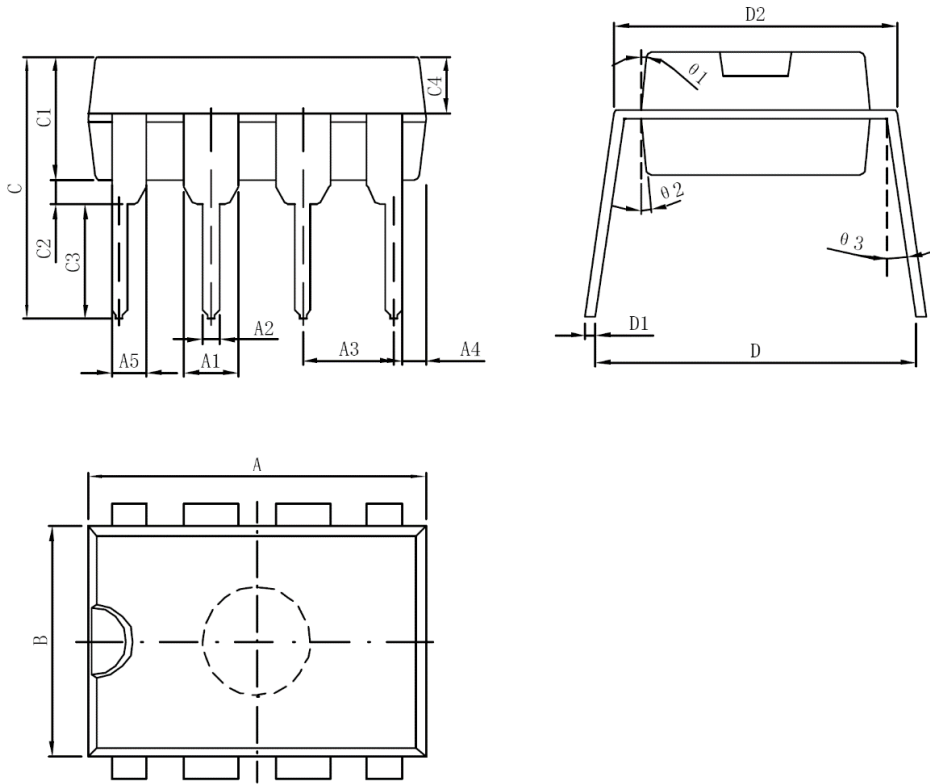

Symbol	Min. (mm)	Max. (mm)	Symbol	Min. (mm)	Max. (mm)
A	9.30	9.50	C2	0.50	
A1	1.524		C3	3.3	
A2	0.39	0.53	C4	1.57TYP	
A3	2.54		D	8.20	8.80
A4	0.66TYP		D1	0.20	0.35
A5	0.99TYP		D2	7.62	7.87
B	6.3	6.5	theta 1	8°TYP	
C	7.20		theta 2	8°TYP	
C1	3.30	3.50	theta 3	5°TYP	

Special Instructions

The company reserves the right of final interpretation of this specification.

Version Change Description

Version: V1.6

Author: Yangyang

Time: 2021.8.12

Modify the record:

1. Re-typesetting the manual and checking some data
-

Statement

The information in the usage specification is correct at the time of publication, Shanghai Siproin Microelectronics Co.,Ltd. has the right to change and interpret the specification, and reserves the right to modify the product without prior notice. Users can obtain the latest version information from our official website or other effective channels before confirmation, and verify whether the relevant information is complete and up to date.

With any semiconductor product, there is a certain possibility of failure or failure under certain conditions. The buyer is responsible for complying with safety standards and taking safety measures when using the product for system design and complete machine manufacturing. The product is not authorized to be used as a critical component in life-saving or life-sustaining products or systems, in order to avoid potential failure risks that may cause personal injury or property loss.